

Norberto "Beto" Salinas, Mayor
Norie Gonzalez Garza, Mayor Pro Tem
Jessica Ortega-Ochoa, Councilwoman

Ruben Plata, Councilman
Dr. Armando O'caña, Councilman
Martin Garza Jr., City Manager

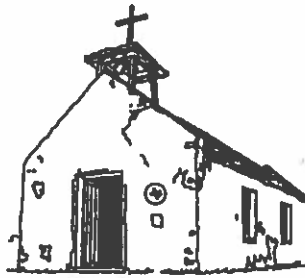

CITY OF MISSION

"Home of the Grapefruit"

March 21, 2017

RE: **Addendum No. 1/Teller Drive-thru Replacements**
Request for Bid No.: 17-146-03-31

Dear Prospective Bidder:

The following is to be corrected/added/changed/clarified:

- a. This addendum is being provided to all bidders. Changes are marked with a vertical line on the right hand side.
- b. See corrected Plans and Specifications. Sheet numbers and title changes. Dimensions, figures and models stay the same with the exception of the attachment.
- c. The bid due date has not changed. The date for receipt of bids is **Friday, March 31st, 2017 at 2:00 PM CST.**

NOTE: This form must be completed and submitted with your bid response. WARNING: Failure of an Offeror to acknowledge receipt of this Addendum, as described herein, may result in REJECTION OF THE OFFER.

We apologize for any inconvenience this may have caused. Authorized signature is needed. Everything else shall remain the same. If you have any questions, please contact me at (956) 580-8667.

Sincerely,

Eduardo Belmarez,
Purchasing Director

_____ Acknowledge receipt of Addendum No. 1
Authorized Signature

Printed Name

Company Name

Teller Drive-thru Replacements RFB 17-146-03-31



CITY OF MISSION

**660/880 PNEUMATIC TUBE SYSTEMS
STANDARD CUSTOMER UNIT (4.0/4.5)**

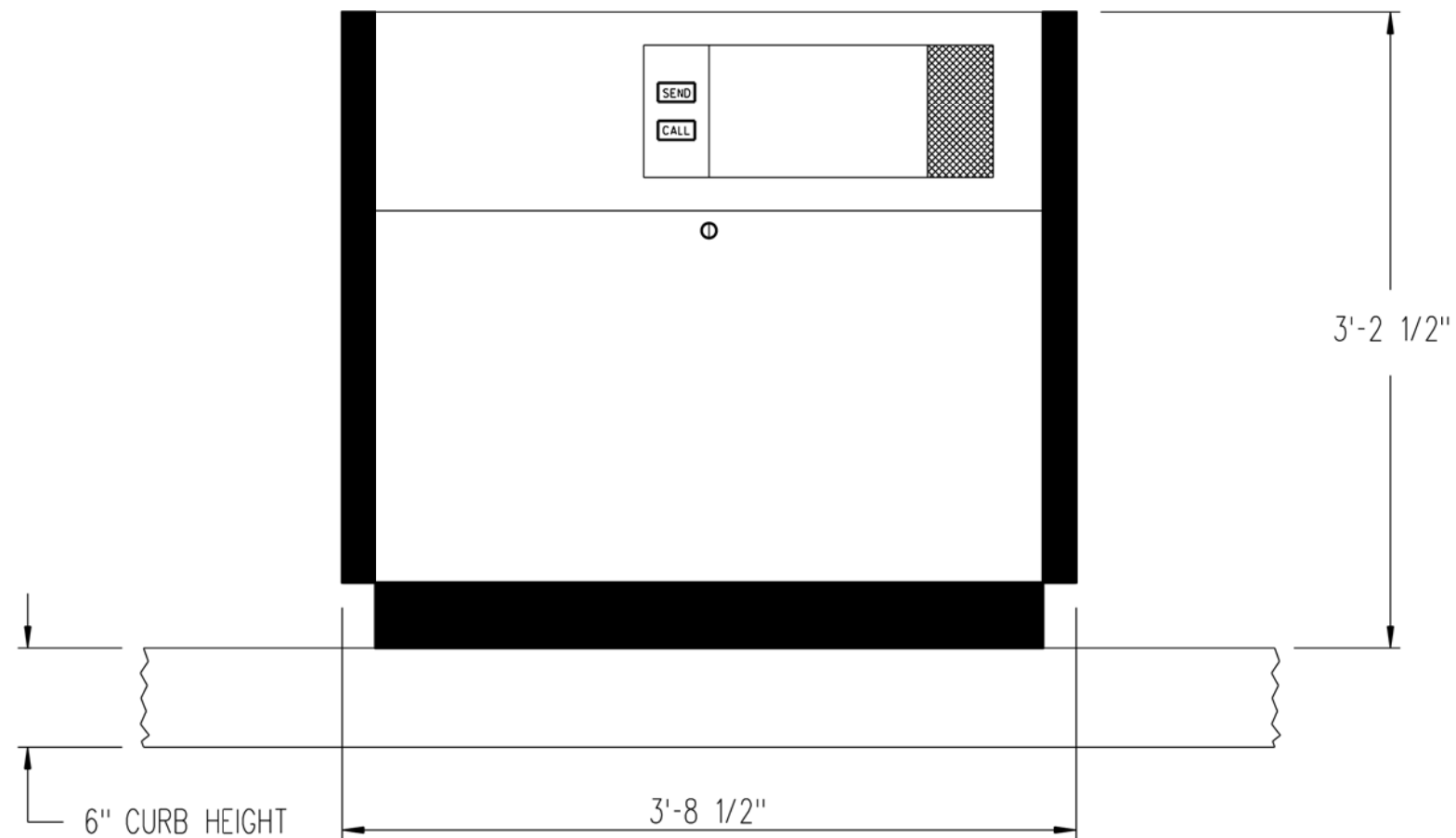
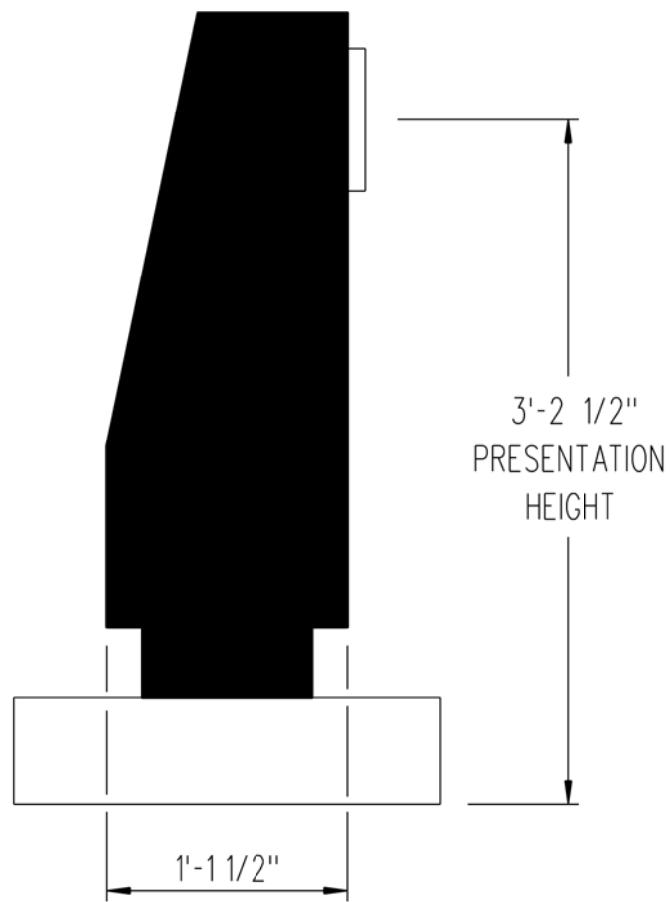
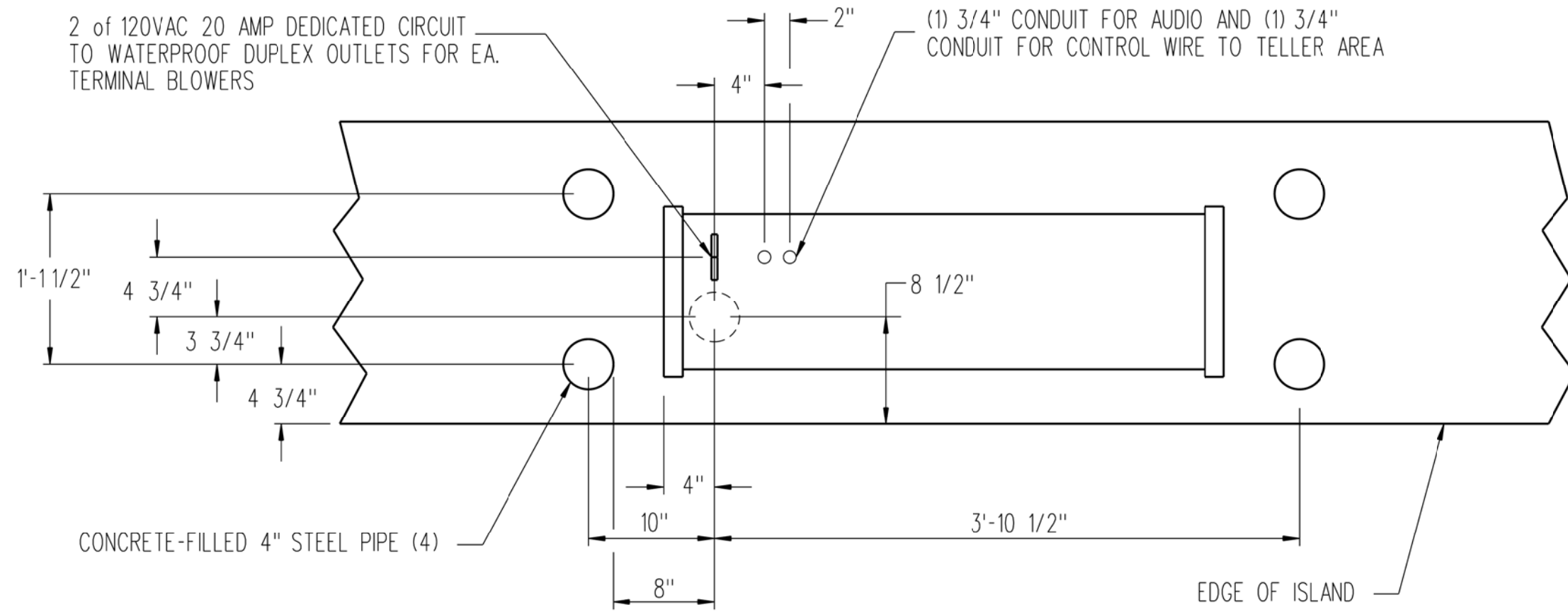

Project Name:

CITY OF MISSION
WATER BILL DEPT.
TELLER UNITS

Date: 3-24-17

Project No: 005-17

Sheet Number:

M-1



CITY OF MISSION

**MODEL 660/880 PNEUMATIC
TUBE SYSTEM TYPE O TELLER UNIT**

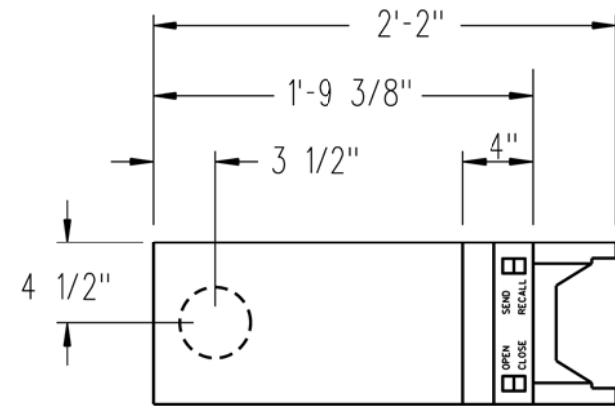

UNDER COUNTER, UNDERGROUND
WITH AUTO-DISPATCH.

120VAC 15 AMP SERVICE REQUIRED
WITH 3' OF UNIT OR SUPPLIED VIA
CONDUIT IN FOUNDATION WITHIN
FOOTPRINT

REPLACEMENT:
MOSSLER-PV1, TV1, TV2, TV3
DIEBOLD-VAT2, VAT4, VAT6
NATIONAL-SL5010
SECURITY-ALL MODELS
MEILINK-4.0"

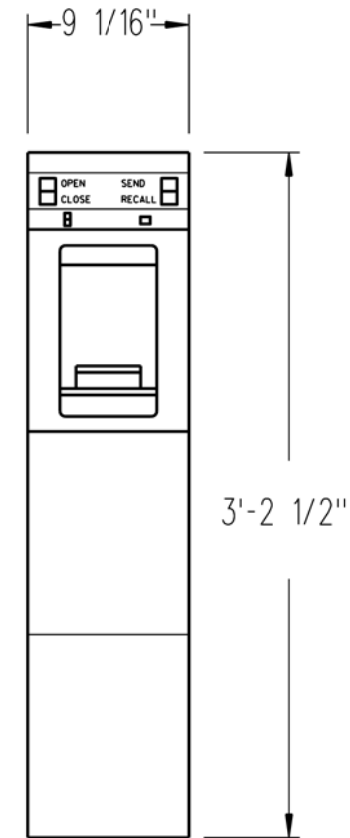
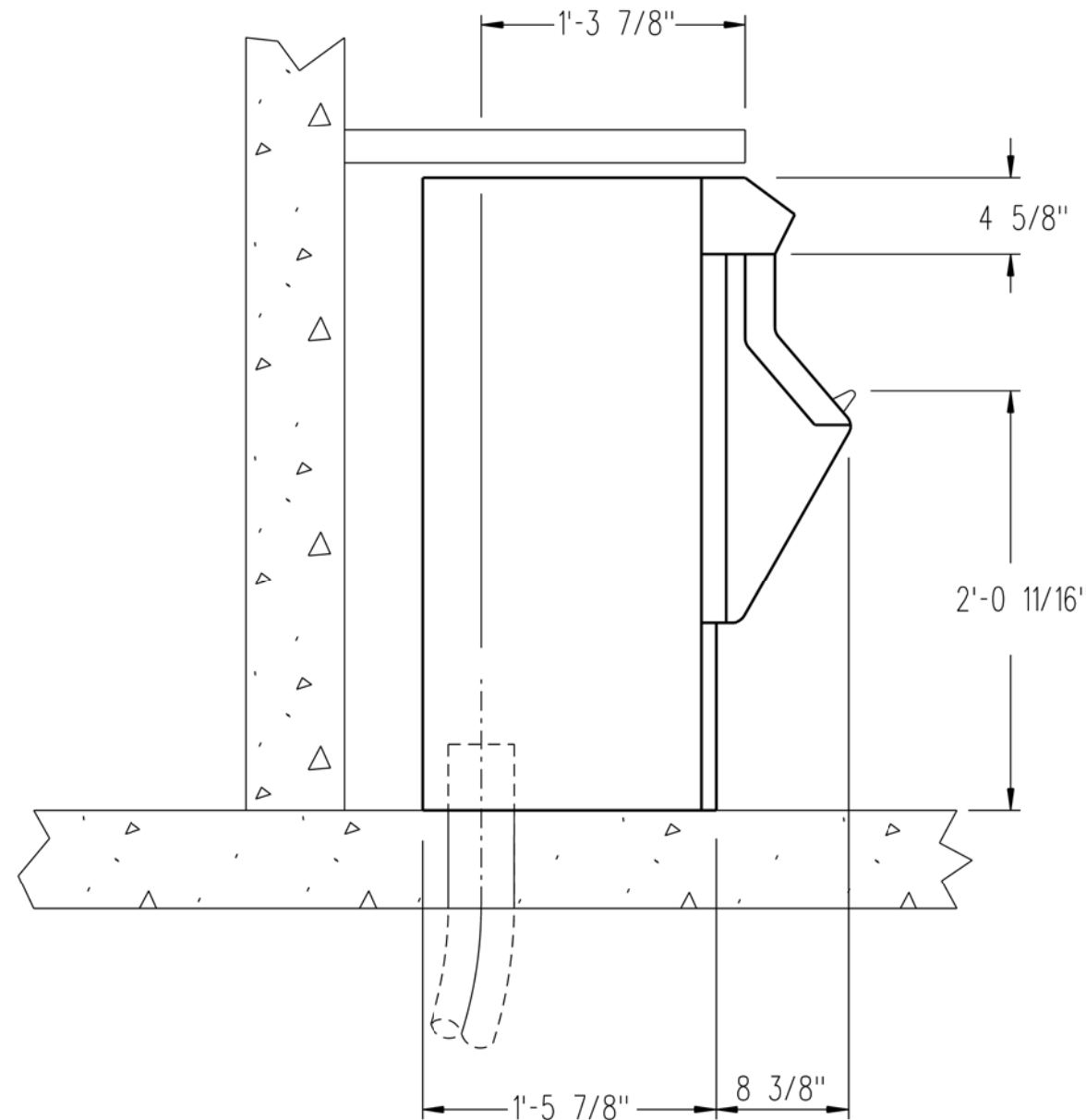

Project Name:

CITY OF MISSION
WATER BILL DEPT.
TELLER UNITS

Date: 3-24-17

Project No: 005-17

Sheet Number:

M-2



CITY OF MISSION

**MODEL 523 CU REMOTE
CUSTOMER UNIT DETAILS**

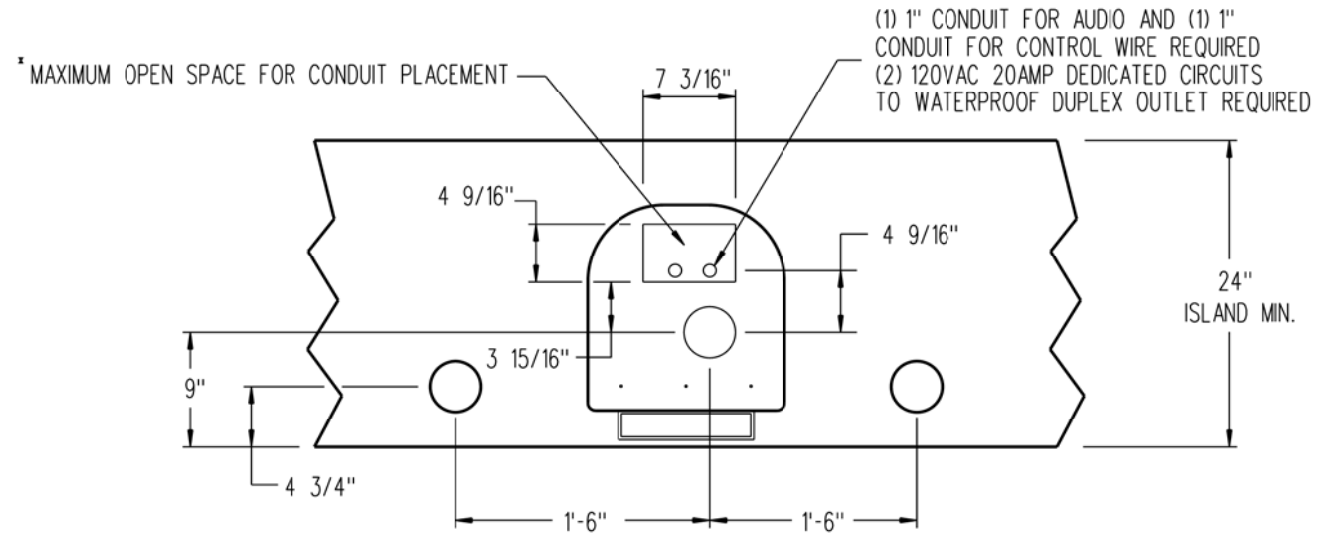

PLAN VIEW

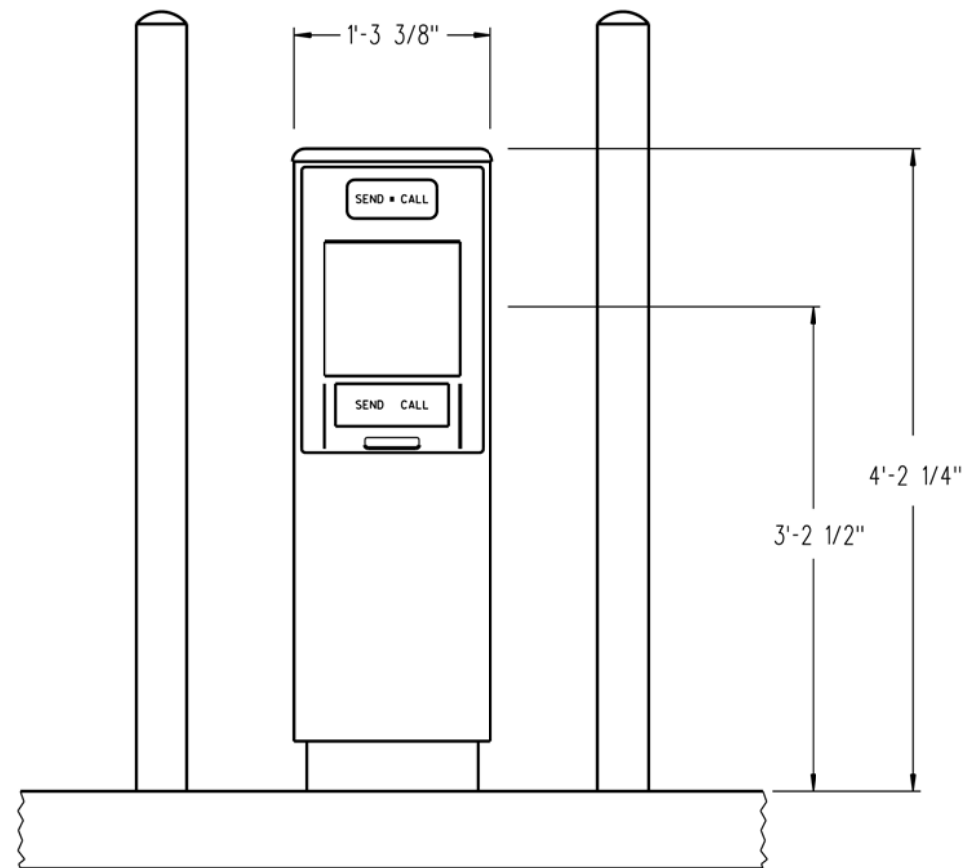

FRONT VIEW

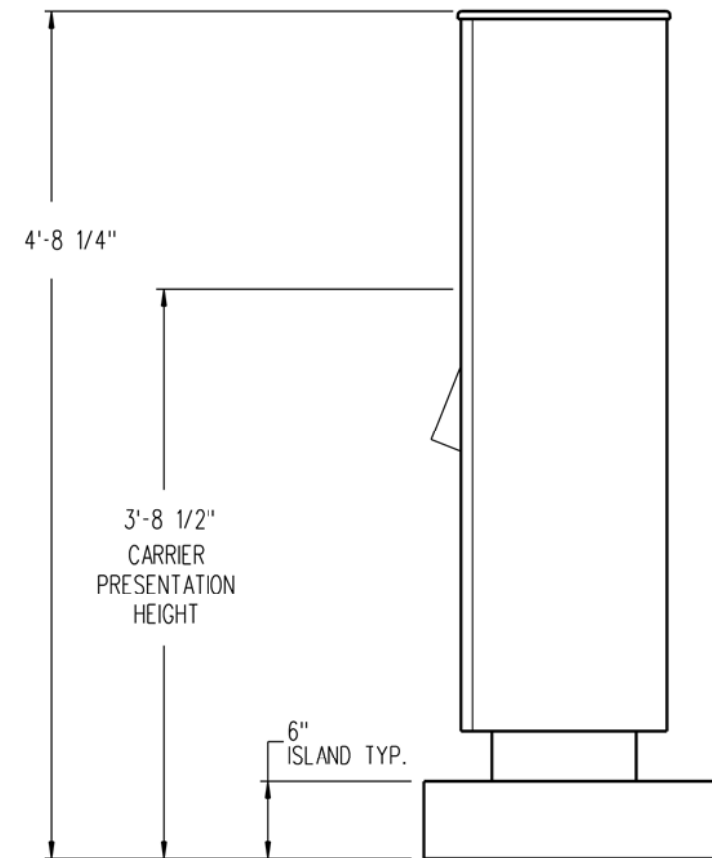

SIDE VIEW

Project Name:	
CITY OF MISSION WATER BILL DEPT. CUSTOMER UNITS	
Date:	3-24-17
Project No:	005-17
Sheet Number:	



CITY OF MISSION

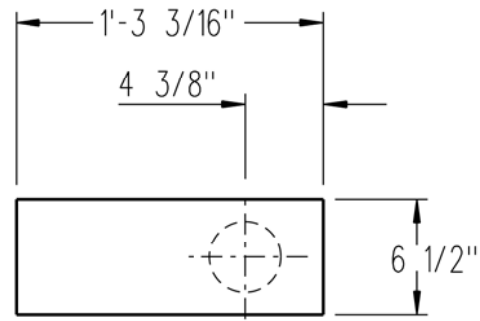

PLAN VIEW

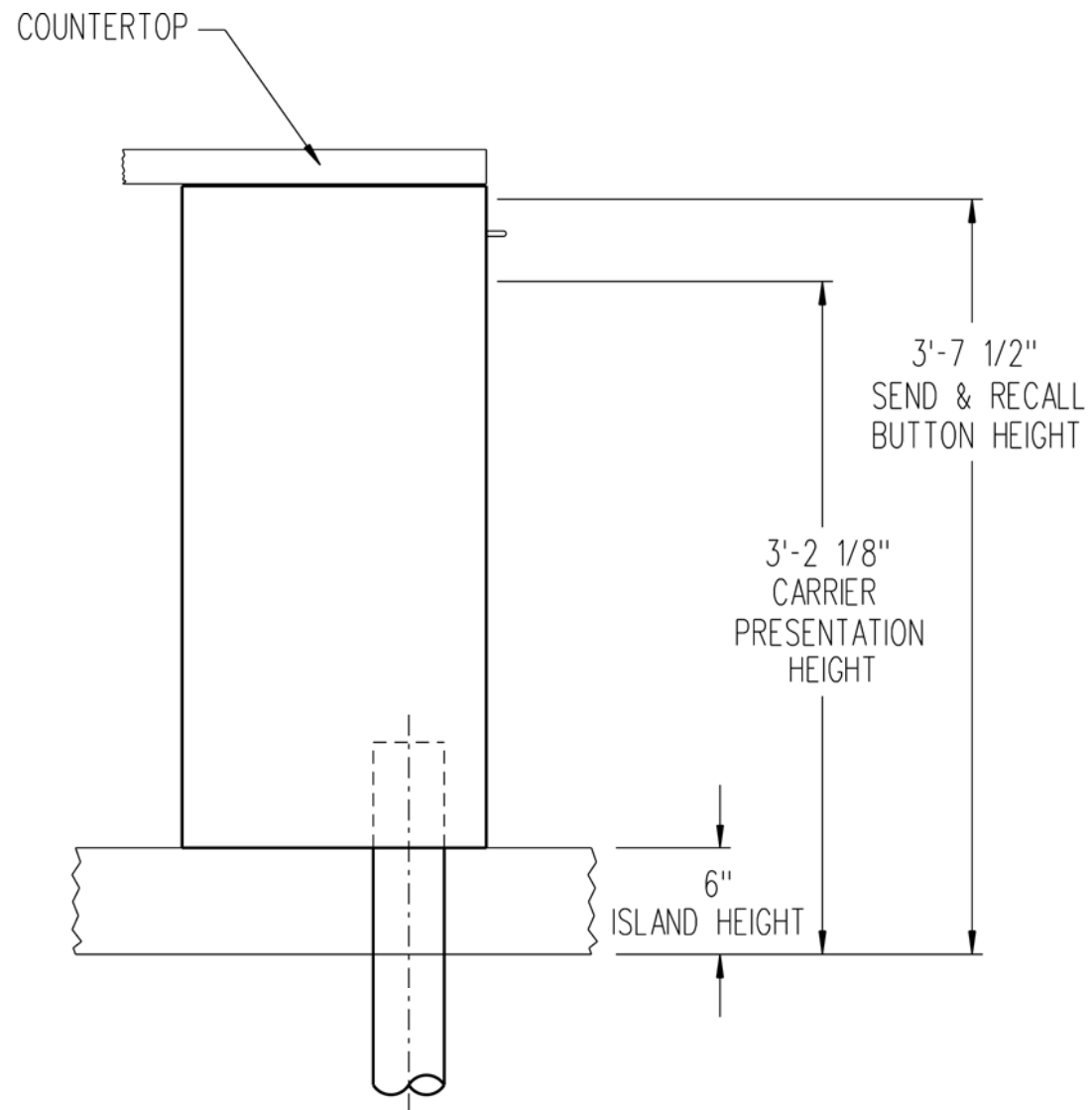

SIDE VIEW

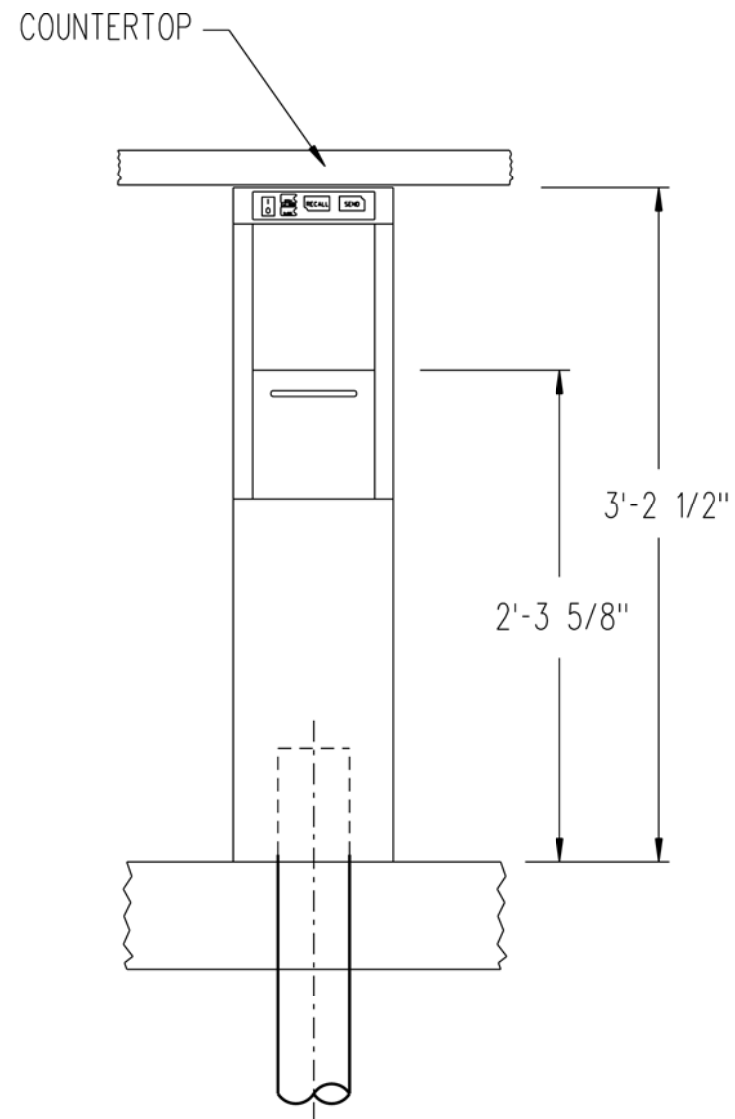

FRONT VIEW

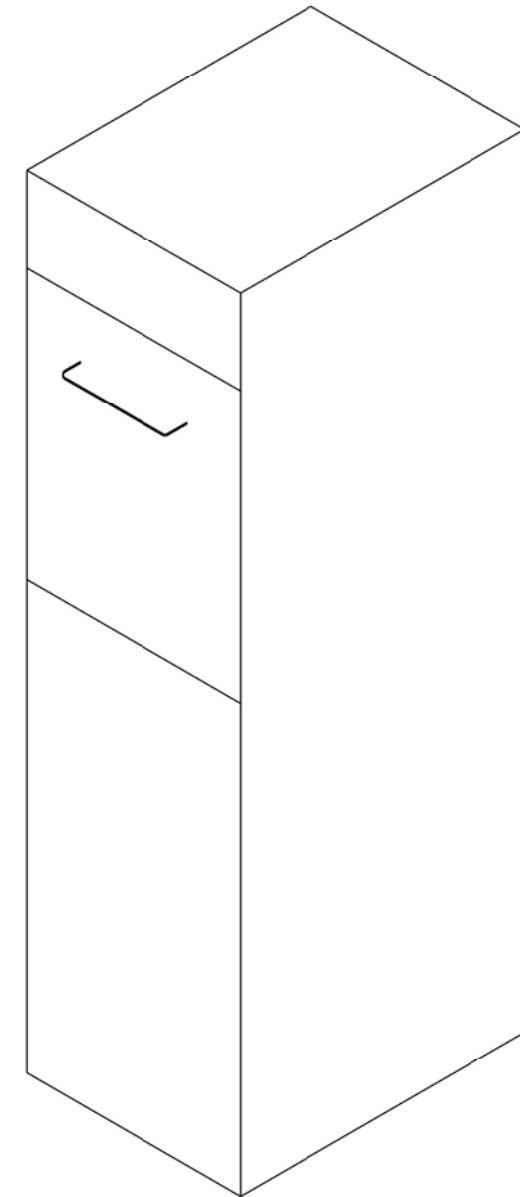

ISO VIEW

**523 PNEUMATIC TUBE SYSTEMS
TYPE 3 TELLER UNIT DETAILS**

Project Name:

CITY OF MISSION
WATER BILL DEPT.
TELLER UNITS

Date: 3-24-17

Project No: 005-17

Sheet Number:

M-4